

RED indicates NEW information



Low Voltage Supplementary Fuses

Section Contents

	Page
Fuse Holder & Block Selection Guide	44-45
Cable limiters & welder limiters	
K Series cable limiters 600V	46
64000 & 68000 welder limiters . . . 600V	46
1³/₃₂" x 1 1/2" Fast-acting supplementary fuses	
BAF 250V	47
KTK 600V	47
KLM 500V	47
DCM 600Vac/dc	47
Solar PV 250V	48
1³/₃₂" x 1 1/2" Time-delay supplementary fuses	
FNM 250V	49
FNQ 500V	49
1³/₃₂" x 1 3/8" Fast-acting supplementary fuses	
BBS 600V	50
KTQ 600V	50
Pin indication fuses and actuator	
GBA 125V	51
GLD 125V	51
MIC 250V fast-acting	51
MIN 250V fast-acting	51
FNA 250V time-delay	51
MIS 600V	52
KAZ 600V	52
Limiters	
ANN 125V fast-acting	52
ANL 80Vdc time-delay	52
4164 & 4164-FR fuse blocks	52
In-line size rejecting fuses and fuse holders	
GLQ 300V	53
GMQ 300V	53
In-line non-rejecting fuses and fuse holders	
GLR 300V	54
GMF 300V	54
GRF 300V	54
Automotive blade-type fuses	
ATC 32Vdc	55
ATC-ID 32Vdc	55
ATM 32Vdc	55
ATM-ID 32Vdc	55
MAX 32Vdc	55
MAX-ID 32Vdc	55
Automotive blade-type fuse holders	
HHC, HHD, HHF, HHG, ATC-FHID for ATC fuses	56
HHL, HHM, ATC-FHID for ATM fuses	56
HHX for MAX fuses	56

Low Voltage Supplementary Fuses

Holders & Blocks for Low Voltage Supplementary Fuses

Limiters

Catalog Number	Volts	Page
K Series	600V	46
68000 Series	600V	46
64000 Series	600V	46
ANN Fast acting limiter	125Vac/80Vdc	52
ANL Time-delay limiter	80Vdc	52

Holders

- CH Series Class J modular 1 to 3-pole, panel/DIN rail mount . . .254
- Safety J™ Series modular holders, panel/DIN rail mount255

Blocks

- Modular Type Fuse Blocks 250/600V, panel mount275
- H250 Series 1- to 3-pole 250V, panel mount260
- H600 Series 1- to 3-pole 600V, panel mount263

Blocks

- Modular Type Fuse Blocks 600V, panel mount 275
- J600 Series, panel mount 266
- JP Series pyramid blocks, panel mount 268
- BH Series modular-style open blocks, panel mount 275

Limiter Blocks - ANN & ANL

- Blocks for 4164 & 4164-FR 52



CH Series



Safety J™ Series



Modular Type



H250 Series



H600 Series



J600 Series



JP Series



BH Series



4164 & 4164-FR

1 3/8" X 1 1/2" Fuses

Catalog Number	Volts	Page
BAF	250V	47
KTK	600V	47
KLM	600Vac/dc	47
DCM	600Vac/dc	47
Solar PV	250V	48
FNM	250V	49
FNQ	500V	49

Holders

- OPM-NG-SC3 3-pole, panel/DIN rail mount252
- OPM-1038R 3-pole, panel/DIN rail mount251
- OPM-1038RSW 3-pole w/ switch, panel/DIN rail mount250
- CH Series Global 1- to 3-pole, DIN rail mount259
- HPG Panel mount fuse holder286
- HPC-D Panel mount fuse holder287
- HPM Panel mount fuse holder287
- HPS Series Panel mount fuse holder286
- HPF Series Panel mount fuse holder286
- HEB Series 1-Pole in-line fuse holder279
- HEX & HEY Series 2-Pole in-line fuse holders279
- NDNF1-WH Fuse holding rail mount terminal block 291

Blocks

- BM Series, panel/DIN rail with adapters 274
- 3723, 3742 and 3743 multi-pole add-on fuse blocks 290



OPM-NG-SC3



OPM-1038R & OPM-1038RSW



CH Series



HPG



HPC-D



HPM



HPS



HPF



HEB Series



HEX & HEY Series



NDNF1-WH



BM Series

Holders & Blocks for Low Voltage Supplementary Fuses

1 3/32" X 1 3/8" Fuses

Catalog Numbers	Volts	Page
BBS	600V	50
KTO	600V	50

Holder

- HPS-L Panel mount holder286

Blocks

- BM Series, panel/DIN rail with adapters274
- 3723, 3742 and 3743 multi-pole add-on fuse blocks290



HPS-L



BM Series

Low Voltage Supplementary Fuses

Pin Indicating Fuses

1/4" X 1 1/4" Fuse Catalog Numbers	Volts	Page
GBA 1/4" X 1 1/4"	.125V	51
GLD 1/4" X 1 1/4"	.125V	51
MIC 1 3/32" X 1 1/2"	.250V	51
MIN 1 3/32" X 1 1/2"	.250V	51
FNA 1 3/32" X 1 1/2"	.250V	51
MIS 1 3/32" X 2"	600V	52
KAZ 1 3/32" X 2"	600V	52



HLD



HK Series

Holders

- 1/4" X 1 1/4": HLD Panel mount visual indication285
- 1/4" X 1 1/4": HK Series Panel mount lamp indicating285

Blocks

- 1/4" X 1 1/4": Series 8000 for visual indication288
- 1 3/32" X 1 1/2": 1-Pole signal block cat. # 3839 (not shown in catalog)*
- 1 3/32" X 2": 1-Pole signal block cat. # 2778 (not shown in catalog)*
- 1 3/32" X 2": 2-Pole signal block cat. # 2837 (not shown in catalog)*
- 1 3/32" X 2": 3-Pole signal block cat. # 2838 (not shown in catalog)*

*Call our customer satisfaction team at 636-527-3877 for more information.



Series 8000

Automotive Blade-type Fuses

Catalog Numbers	Volts	Page
ATC	32Vdc	55
ATM	32Vdc	55
MAX	32Vdc	55

Holders

- ATC: HHC, HHD, HHF, HHG & ATC-FHID In-line holders56
- ATM: HHL, HHM & ATM-FHID In-line holders56
- MAX: HHX In-line holders56



HHC, HHD, HHF & HHG



HHL & HHM



HHX

In-Line Rejecting and Non-Rejecting Fuses

Catalog Number	Volts	Page
GLQ rejecting fuse	300V	53
GMQ rejecting fuse	300V	53
GLR non-rejecting fuse	300V	54
GMF non-rejecting fuse	300V	54
GRF non-rejecting fuse	300V	54

Holders

- GLQ & GMQ: HLO Rejection holder53
- GLR, GMF & GRF: HLR & HLR-2A non-rejection holders54



HLO³ Fuse Holders



HLR Fuse Holder

Cable Limiters & Welder Limiters

K Series

Specifications

Description: Cable limiters.

Ratings:

- Volts — 600Vac
- IR — 200,000A RMS Sym.
@ 600Vac

Agency Information: UL

Listing: KDM, KDR, KDP and KFM, KCM, KCM-B and KCR.

Features and Benefits

- Sizes and ratings available to meet many applications.

Typical Applications

- Protecting low voltage distribution and service entrance cables against short-circuit currents.

Catalog Numbers

Copper Cable Limiter — 600 Volts

Catalog Number	Cable Size	Catalog Number	Cable Size
----------------	------------	----------------	------------

Tubular Terminals

KCY	#4	KCF	4/0
KCZ	#3	KCH	250 MCM
KCA	#2	KCJ ^{1, 2}	350 MCM
KCB	#1	KCM ^{1, 2, 3} , KCM-B ¹	500 MCM
KCC	1/0	KCV	600 MCM
KCD ^{1, 2}	2/0	KCR ^{1, 2}	750 MCM
KCE	3/0	KCS	1000 MCM

Tubular Terminal and Offset Bolt-Type Terminal

KQV	#12	KDD ¹	2/0
KQT	#10	KDE	3/0
KFZ	#8	KDF	4/0
KIG	#6	KDH	250 MCM
KDY	#4	KDJ ^{1, 2}	350 MCM
KDA	#2	KDM ^{1, 2, 3}	500 MCM
KDB	#1	KDU	600 MCM
KDC	1/0	KDR ^{1, 2}	750 MCM

Compression Connector Rod and Tubular Terminals

KEX	4/0	KQO	350 MCM
KFH-A	250 MCM	KDT ¹	500 MCM

*Center Bolt-Type Terminal and Off-Set Bolt-Type Terminal

KPF	4/0	KDP ¹	500 MCM
KFT ¹	250 MCM	KFM ¹	750 MCM
KEW ¹	350 MCM		

¹Copper or aluminum cable; sizes of all other limiters pertain to copper only.

²UL Listed (File E90818).

³Available with shrink tube “_V” suffix.

⁴Available with molded rubber boots. Add “-B” to end of part number.

Accessories

Boots can be purchased separately.

For KCM Boot-KCM

For KDM Boot-KDM

Installation tools can be purchased separately from Thomas and Betts

• Crimp Tool: TBM-14M

• Die: 15506 KDM/15515 KDR

64000 & 68000 Series

Specifications

Description: Welder limiters.

Ratings:

- Volts — 600Vac (or less)
- IR — 200,000A RMS Sym.

Features and Benefits

- Current-limiting devices designed specially for use on welder circuits only
- Time-current characteristics are designed to hold on the intermittent overloading encountered in welder operation, while providing short-circuit protection to the circuit and equipment
- Welder limiters have excess current capacity in the operating range as needed for this type of service

Typical Applications

- Welder circuits
- Because welder limiters have special characteristics, they are not intended for application on general-use circuits

Catalog Numbers

Catalog Numbers	Fuse Holder Type	Nominal Amp Rating
68150	Class H	150
68200	Class H	200
68300	Class H	300
68400	Class H	400
68600	Class H	600
64200	Class J	200
64300	Class J	300
64400	Class J	400
64600	Class J	600

Recommended Fuse Blocks For 68000 & 64000 Series limiters

- See page 44

Data Sheet: 1045

Data Sheet: 1042

1 3/32" x 1 1/2" Fast-acting Fuses

BAF

Specifications

Class: Supplemental
Description: Fast-acting supplementary fuse.
Dimensions: 1 3/32" x 1 1/2" (10.3 x 38.1mm).

Ratings:

Volts — 250Vac (or less)
 Amps — 1/10-30A
 IR — 10kA @ 125Vac (1/10-30A)
 — 35A (1/10-1A @ 250Vac)
 — 100A (1 1/2-3A @ 250Vac)
 — 200A (4-10A @ 250Vac)
 — 750A (12A- 15A @ 250Vac)
 — 200A (20-30A @ 250Vac)

Agency Information: CE, Std. 248-14, UL 0-15/250V, Guide JDYX, File E19180 CSA Certified, 0-15/250V, Class 1422-01, File 53787.

Features and Benefits

- Low cost supplemental protection of 125V and 250V non-inductive circuits.
- Upgrade with LP-CC product to reduce SKU investment and minimize potential arc-flash hazards. (and minimize potential for misapplying fuse.)

Typical Applications

- General Purpose Circuits
- Lighting Circuit Protection
- Meter Circuits

Catalog Numbers (Amps)

BAF-1/10	BAF-2	BAF-8
BAF-1/4	BAF-2-1/2	BAF-9
BAF-1/2	BAF-3	BAF-10
BAF-3/10	BAF-4	BAF-12
BAF-3/10	BAF-5	BAF-15
BAF-1	BAF-6	BAF-20
BAF-1-1/2	BAF-6-1/2	BAF-25
BAF-1-3/10	BAF-7	BAF-30

*All have interrupting rating of 10,000A at 125V.

For superior electrical protection, Cooper Bussmann recommends upgrading BAF and fuse applications to Low-Peak LP-CC fuses See page 17.

Data Sheet: 2011 (0-30)



KTK

Specifications

Class: Supplemental
Description: Fast-acting supplementary fuse.
Dimensions: 1 3/32" x 1 1/2" (10.3 x 38.1mm).

Ratings:

Volts — 600Vac (or less)
 Amps — 1/10-30A
 IR — 100kA RMS Sym. (UL)

Agency Information: CE, Std. 248-14, UL Listed, Guide JDYX, File E19180.

Features and Benefits

- Low cost supplemental protection of 600V or less non-inductive circuits.
- Upgrade with LP-CC product to reduce SKU investment and minimize potential arc-flash hazards.

Typical Applications

- Control Circuits
- Lighting Circuit Protection
- Meter Circuits

Catalog Numbers (Amps)

600Vac - UL Listed and CSA				
KTK-1/10	KTK-1/4	KTK-4	KTK-12	KTK-50*
KTK-1/8	KTK-1	KTK-5	KTK-15	
KTK-1/10	KTK-1-1/4	KTK-6	KTK-20	
KTK-1/4	KTK-1-1/2	KTK-7	KTK-25	
KTK-3/10	KTK-2	KTK-7-1/2	KTK-30	
KTK-3/10	KTK-2-1/2	KTK-8	KTK-35*	
KTK-1/2	KTK-3	KTK-9	KTK-40*	
KTK-3/10	KTK-3-1/2	KTK-10	KTK-45*	

*Rated for no more than 24A continuous.

For superior electrical protection, Cooper Bussmann recommends upgrading KTK fuse applications to Low-Peak LP-CC fuses See page 17.

Data Sheet: 1011



DCM & KLM

Specifications

Class: Supplemental
Description: Full range, fast-acting, DC midget fuse.

Dimensions:

1 3/32" x 1 1/2" (10.3 X 38.1mm).

Ratings:

Volts — 600Vac/dc
 Amps — 1/10-30A
 IR — 100kA AC
 — 50kA DC

Agency Information: CE, UL Listed: STD. 248-14, (FILE #E19180, GUIDE #JDYX), CSA Certified, C22.2 NO. 248. 14 (CLASS #1422-01, FILE #53787).

Features and Benefits

- Full range, fast-acting, 600Vac/dc midget fuse.
- Minimum interrupting rating or 200% rated current at 600Vdc.

Typical Applications

- DC Control Circuits Requiring Fast-Acting Fuses.
- Solar power energy sources.

Catalog Numbers (Amps) - DCM

DCM-1/10	DCM-1	DCM-5	DCM-15
DCM-1/8	DCM-1-1/4	DCM-6	DCM-20
DCM-3/10	DCM-1-1/2	DCM-7	DCM-25
DCM-1/4	DCM-2	DCM-8	DCM-30
DCM-3/10	DCM-2-1/2	DCM-9	
DCM-1/2	DCM-3	DCM-10	
DCM-3/10	DCM-4	DCM-12	

Catalog Numbers (Amps) - KLM

KLM-1/10	KLM-1/4	KLM-5	KLM-20
KLM-1/8	KLM-1	KLM-6	KLM-25
KLM-3/10	KLM-1-1/2	KLM-8	KLM-30
KLM-1/4	KLM-2	KLM-10	
KLM-3/10	KLM-3	KLM-12	
KLM-1/2	KLM-4	KLM-15	

Data Sheet: DCM 2038 KLM 2020



Low Voltage Supplementary Fuses

Recommended fuse blocks/fuse holders for 1 3/32" x 1 1/2" fuses

- See page 44

Fuses for Solar Panel Applications

PV

Specifications

Class: gPV

Description: A range of fuses specifically designed for the protection and isolation of photovoltaic strings.

Dimensions: $\frac{13}{32}$ " x $1\frac{1}{2}$ "
(10.3 x 38.1mm).

Ratings:

Volts — 1000Vdc

Amps — 1-15A

IR — 33kAdc

IR (Min) — $1.3 \times I_n$

Agency Information: UL Pending, CE, IEC 60269.

Features and Benefits

- Capable of interrupting low over currents associated with faulted PV strings.
- High DC voltage rating.
- Variety of mounting options for flexibility.

Catalog Numbers (Amps)

PV-1A10F	PV-3A10F	PV-5A10F	PV-8A10F	PV-12A10F
PV-2A10F	PV-4A10F	PV-6A10F	PV-10A10F	PV-15A10F

For bolt-on tabs, replace 'F' with '-T'

For PCB mounting, replace 'F' with '-1P' or '-2P'



Dimensions - (mm)

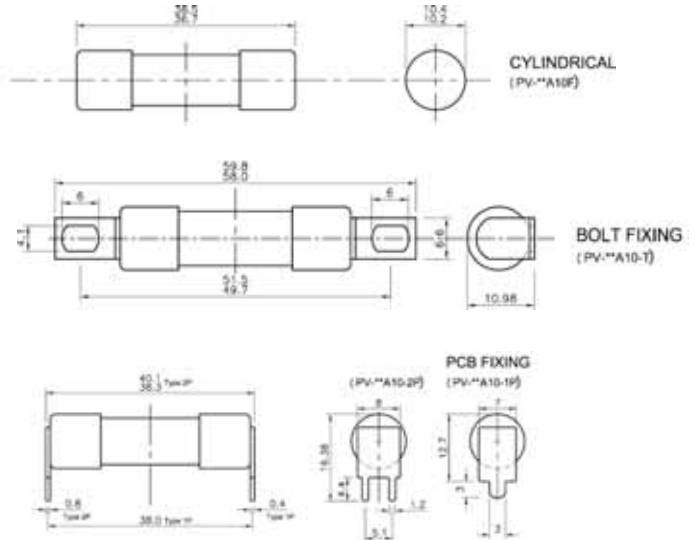

Time-Current Characteristic Curves—Average Melt

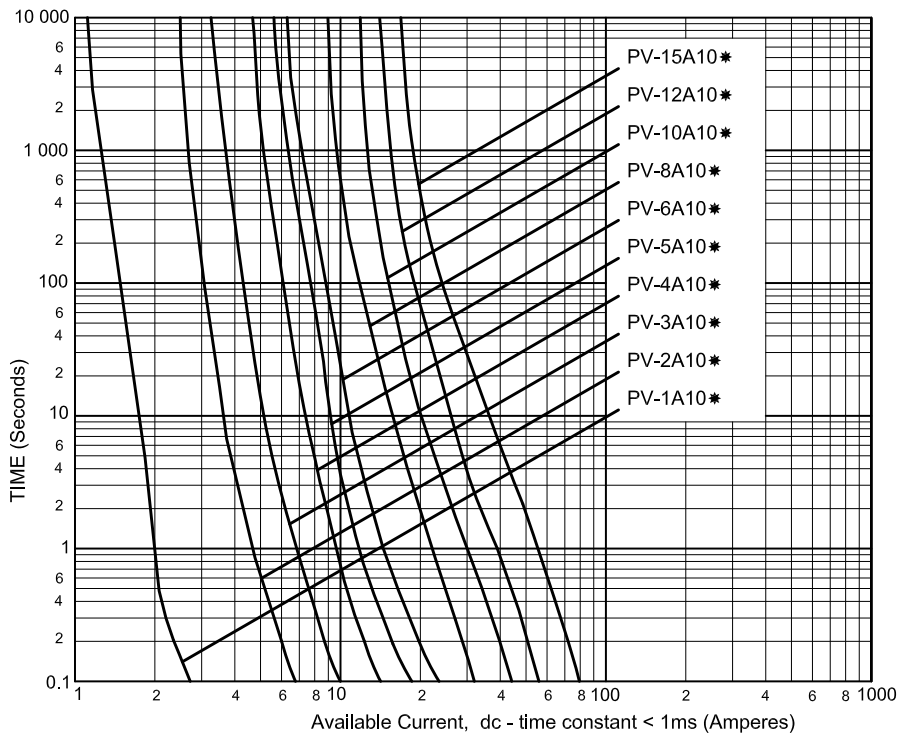

1³/₃₂" x 1¹/₂" Time-delay Fuses

FNM

Specifications

Class: Supplemental

Description: Time-delay supplementary fuse.

Dimensions: 1³/₃₂" x 1¹/₂" (10.3 x 38.1mm).

Ratings:

Volts — 250Vac (or less)

Amps — 1/10-30A

- IR — 35A (1/10-1A @ 250Vac)
- 100A (1 1/8-3 1/2A @ 250Vac)
- 200A (4-10A @ 250Vac)
- 10kA (1/10-10A @ 125Vac)
- 10kA (12-30A @ 250Vac)

Agency Information: CE, Std. 248-14, UL Listed, 0-30/250Vac; File E19180, Guide JDYX, CSA Certified, 1-30/250Vac; Class 1422-01, File 53787.

Features and Benefits

- Low cost supplemental protection of 125V and 250V inductive circuits.

Typical Applications

- General Purpose Circuits
- Lighting Circuit Protection
- Meter Circuits
- Upgrading to LP-CC product will reduce SKU investment and minimize potential for misapplying fuse.

Catalog Numbers (Amps)

FNM-1/10	FNM-1/2	FNM-1-1/2	FNM-3	FNM-6	FNM-15
FNM-1/8	FNM-3/10	FNM-1-3/10	FNM-3-3/10	FNM-6-1/4	FNM-20
FNM-15/100	FNM-3/4	FNM-1-9/10	FNM-3-1/2	FNM-7	FNM-25
FNM-7/10	FNM-1	FNM-2	FNM-4	FNM-8	FNM-30
FNM-1/4	FNM-1-1/8	FNM-2-1/4	FNM-4-1/2	FNM-9	
FNM-3/10	FNM-1-1/4	FNM-2-1/2	FNM-5	FNM-10	
FNM-1/10	FNM-1-1/10	FNM-2-9/10	FNM-5-9/10	FNM-12	



FNQ

Specifications

Class: Supplemental

Description: Time-delay supplementary fuse.

Dimensions: 1³/₃₂" x 1¹/₂" (10.3 x 38.1mm).

Ratings:

Volts — 500Vac (or less)

Amps — 1/10-30A

IR — 10kA RMS Sym.

Agency Information: CE, Std. 248-14, UL Listed, Guide JDYX, File E19180 CSA Certified, Class 1422-01, File 53787.

Features and Benefits

- Low cost supplemental protection of transformers and relays at 500V or less.

Typical Applications

- Control Transformer 480V Primary Protection
- Lighting Circuit Protection
- Meter Circuits

Catalog Numbers (Amps)

FNQ-1/10	FNQ-1/2	FNQ-1-1/2	FNQ-3-1/2	FNQ-7	FNQ-20
FNQ-1/8	FNQ-1/2	FNQ-1-3/10	FNQ-4	FNQ-8	FNQ-25
FNQ-15/100	FNQ-3/10	FNQ-2	FNQ-4-1/2	FNQ-9	FNQ-30
FNQ-3/16	FNQ-9/10	FNQ-2-1/4	FNQ-5	FNQ-10	
FNQ-2/10	FNQ-1	FNQ-2-1/2	FNQ-5-9/10	FNQ-12	
FNQ-1/4	FNQ-1-1/8	FNQ-3	FNQ-6	FNQ-14	
FNQ-1/10	FNQ-1-1/4	FNQ-3-3/10	FNQ-6-1/4	FNQ-15	



Low Voltage Supplementary Fuses

For superior electrical protection, Cooper Bussmann recommends upgrading FNM and FNQ fuse applications to Low-Peak LP-CC fuses See page 17.

Recommended fuse blocks and fuse holders for

1³/₃₂" x 1¹/₂" fuses

- See page 44

$1\frac{3}{32}$ " x $1\frac{3}{8}$ " Fast-acting Fuses

BBS

Specifications

Class: Supplemental

Description: Fast-acting supplementary fuse.

Dimensions: $1\frac{3}{32}$ " x $1\frac{3}{8}$ "
(10.3 x 34.9mm).

Construction: Fiber cartridge.

Ratings:

- Volts — 600Vac ($\frac{1}{0}$ -5A)
- 250Vac (6 - 10A)
- 48Vac (12-30A)

Amps — $\frac{1}{0}$ -30A

IR — 10kA RMS Sym.

Agency Information: CE, Std. 248-14, UL Listed, 0-5A/600V, Guide JDYX, File E19180, CSA Certified, 0-5A/600V, Class 1422-01, File 53787.

Features and Benefits

- Low cost supplemental protection of non-inductive circuits
- Reduced interchangeability with other supplemental fuses minimizes misapplication

Typical Applications

- Control Circuits
- Lighting Ballasts
- Meter Circuits

Catalog Numbers (Amps)

BBS- $\frac{1}{0}$	BBS- $\frac{1}{10}$	BBS-4	BBS-15
BBS- $\frac{1}{20}$	BBS-1	BBS-5	BBS-20
BBS- $\frac{1}{4}$	BBS-1- $\frac{1}{2}$	BBS-6	BBS-25
BBS- $\frac{1}{10}$	BBS-1- $\frac{1}{10}$	BBS-7	BBS-30
BBS- $\frac{1}{2}$	BBS-1- $\frac{3}{10}$	BBS-8	
BBS- $\frac{1}{10}$	BBS-2	BBS-10	
BBS- $\frac{1}{4}$	BBS-3	BBS-12	



KTQ

Specifications

Class: Supplemental

Description: Fast-acting supplementary fuse.

Dimensions: $1\frac{3}{32}$ " x $1\frac{3}{8}$ "
(10.3 x 34.9mm).

Construction: Fiber cartridge.

Ratings:

- Volts — 600Vac
- Amps — 1-6A
- IR — 10kA RMS Sym.

Agency Information: CE, Std. 248-14, UL Recognized, 4-6A, Guide JDYX2, File E19180.

Features and Benefits

- Low cost supplemental protection of non-inductive circuits
- Rated for application in circuits at 600V or less.
- Reduced interchangeability with other supplemental fuses minimizes misapplication

Typical Applications

- Control Circuits
- Lighting Ballasts
- Meter Circuits

Catalog Numbers (Amps) (600Vac)

KTQ-1	KTQ-3	KTQ-6
KTQ-1- $\frac{1}{10}$	KTQ-4	
KTQ-2	KTQ-5	



Recommended fuse blocks/fuse holders for $1\frac{3}{32}$ " x $1\frac{3}{8}$ " fuses

- Page 45

Pin Indication Fuses

GBA

GLD

Specifications

Class: Supplemental

Description: Fast-acting, pin indication fuse.

Dimensions: ¼" x 1 ¼"
(6.6 x 31.7mm) 3AG.

Ratings:

Volts — See Agency Info below

Amps — ½-15A

IR — See Agency Info below

Agency Information: CE, Std. 248-14, UL Listed, 0-5A/125Vac, 10,000 AIC, Guide JDYX, File E19180, UL Recognized, 6A/125Vac, 1000AIC 8-15A/50Vac/dc, 300 AIC Guide JDYX2, File E19180, CSA Certified: 0-5A/125Vac, 10,000 AIC Class 1422-01, File 53787.

Features and Benefits

- Type GBA has a "red" pin indicator providing visual identification of failed circuits, resulting in faster troubleshooting (reduced circuit downtime).
- Type GLD has a plated pin to activate transmitting a electrical signal to indicate the location of opened circuits, resulting in reduced downtime.

Typical Applications

- Control Circuits
- Electronic Circuits

GLD Catalog Numbers (Amps)

GLD-½	GLD-2	GLD-6
GLD-¾	GLD-3	GLD-10
GLD-1	GLD-4	GLD-12
GLD-1-½	GLD-5	GLD-15

GBA Catalog Numbers (Amps)

GBA-½	GBA-2	GBA-8
GBA-¾	GBA-3	GBA-10
GBA-1	GBA-4	GBA-15
GBA-1-½	GBA-5	

Recommended fuse blocks/fuse holders for ¼" x 1 ¼" indicating fuses

- Page 45

Data Sheet: 2012

MIC & MIN

Specifications

Class: Supplemental

Description: Fast-acting, pin indication fuse.

Dimensions: 1 3/32" x 1 ½"
(10.3 x 38.1mm) 5AG.

Ratings:

Volts — 250Vac
(1-15A)
— 32V (20-30A)

Amps — 1-30A

IR — 35A (1A @250Vac)
— 100A (2-3A @250Vac)
— 200A (5-10A @250Vac)
— 750A (15A @250Vac)
— 10kA (20-30A @32V)
— 35A (1A @250Vac)

Agency Information: CE, Std. 248-14, MIC—0-15A UL Listed, 125Vac/10kA IR Guide JDYX, File E19180, MIN—1-5A CSA Certified, Class 1422-01, File 53787.

Features and Benefits

- Type MIN has a "red" pin indicator providing visual identification of failed circuits, resulting in faster trouble shooting (reduced circuit downtime).
- Type MIC has silver-plated pin transmitting an electrical signal indicating location of a failed circuit, resulting in faster troubleshooting (reduced circuit downtime).

Typical Applications

- Control Circuits
- PLC Circuits
- Electronic Circuits

MIC Catalog Numbers (Amps)

MIC-1	MIC-5	MIC-20
MIC-2	MIC-10	MIC-25
MIC-3	MIC-15	MIC-30

MIN Catalog Numbers (Amps)

MIN-1	MIN-5	MIN-20
MIN-2	MIN-10	MIN-25
MIN-3	MIN-15	MIN-30

Recommended signal block for 1 3/32" x 1 ½" indicating fuses

- Page 45

Data Sheet: 2047

FNA

Specifications

Class: Supplemental

Description: Time-delay, pin indication fuse.

Dimensions: 1 3/32" x 1 ½"
(10.3 x 38.1mm).

Ratings:

Volts — 250Vac (½-¾A)
— 125Vac (1-15A)
— 32V (20-30A)

Amps — ½-30A

IR — 35A (½-¾A @ 250Vac)
— 10kA (½-15A @ 125Vac)
— 1kA (20-30A @ 32V)

Agency Information: CE, Std. 248-14, UL Listed ½-¾A, IR 35A@ 250V, IR 10kA@ 125V, 1-15A, IR 10kA@ 125V, Guide JDYX, File 19180, CSA Certified, 0-¾A/250V, 1-10A/125V, Class 1422-01, File 53787.

Features and Benefits

- FNA has a pin indicator providing visual identification of failed circuits, resulting in reduced circuit downtime.
- Time-delay response allows close sizing on control transformers and relays

Typical Applications

- Control Circuits
- Electronic Circuits

Catalog Numbers (Amps)

FNA-½	FNA-¾	FNA-2-½	FNA-6-¼
FNA-¾	FNA-1	FNA-2-¾	FNA-7
FNA-1-1/100	FNA-1-½	FNA-3	FNA-8
FNA-¾	FNA-1-¼	FNA-3-¾	FNA-9
FNA-¼	FNA-1-1/10	FNA-3-½	FNA-10
FNA-¾	FNA-1-½	FNA-4	FNA-12*
FNA-¾	FNA-1-1/10	FNA-4-½	FNA-15*
FNA-½	FNA-1-1/10	FNA-5	FNA-20*
FNA-¾	FNA-2	FNA-5-1/10	FNA-25*
FNA-¾	FNA-2-¼	FNA-6	FNA-30

*12-30A versions are dual-tube construction

Recommended signal block for

1 3/32" x 1 ½" indicating fuses

- Page 45

Data Sheet: 2029

Low Voltage Supplementary Fuses

Pin Indication Fuse and Actuator, and Limiters

ANN & ANL Limiters

Specifications

Description: Circuit limiters.

ANN: Very fast-acting limiter.

ANL: Time-delay limiter.

Dimensions: 7/8" x 3 3/16"
(22.2 x 81.0mm).

Ratings:

ANN:

Volts — 125Vac
— 80Vdc

Amps — 10-800A

IR — 2500A @ 125Vac
— 2700A @ 80Vdc

ANL:

Volts — 80Vdc

Amps — 35-750A

IR — 2700A @ 80Vdc
— 6000A @ 32Vdc

Agency Information:

ANN: 35-400A @ 125Vac, IR=2500A and 500A @ 80Vdc, IR=2700A: UL Recognized Guide JFHR2, File E56412; CSA Certified Class 1422-30, File 53787, CE for 35-400A.

ANL: UL Recognized, CSA Certified, 35-750A @ 80Vdc, IR = 2700A, Guide JFHR2, File E56412, Class 1422-30, File 53787, SAE J1171.

Features and Benefits

- Fast-acting circuit protection (ANN).
- Time-delay sizing for inductive circuits (ANL).
- Small footprint saves space.
- Window shows limiter status.

Typical Applications

- Fork lifts, Marine, Aviation

ANN Catalog Numbers (Amps)

ANN-10	ANN-90	ANN-225	ANN-400
ANN-35	ANN-100	ANN-250	ANN-500
ANN-40	ANN-125	ANN-275	ANN-600
ANN-50	ANN-150	ANN-300	ANN-700
ANN-60	ANN-175	ANN-325	ANN-800
ANN-80	ANN-200	ANN-350	

ANL Catalog Numbers (Amps)

ANL-35	ANL-125	ANL-250	ANL-500
ANL-40	ANL-130	ANL-275	ANL-600
ANL-50	ANL-150	ANL-300	ANL-675
ANL-60	ANL-175	ANL-325	ANL-750
ANL-80	ANL-200	ANL-350	
ANL-100	ANL-225	ANL-400	



MIS

Specifications

Class: Supplemental

Description: Non time-delay pin indication fuse.

Dimensions: 1/2" x 2"
(10.3 x 50.8mm).

Ratings:

Volts — 600Vac
Amps — 1-12A
IR — 200kA

Features and Benefits

- Type MIS has a pin indicator providing visual identification of failed circuits, resulting in faster troubleshooting (reduced circuit downtime).
- Type MIS can be used in circuits rated 600V or less.
- Type MIS has an interrupting rating of 200kA.

Typical Applications

- 480V Control Circuits
- PLC Circuits

Catalog Numbers (Amps)

MIS-1	MIS-4	MIS-10
MIS-2	MIS-5	MIS-12
MIS-3	MIS-8	

Test Specifications

Fuse	Load	Opening Time
All	110%	0 4 hrs. (min.)
1-5A	150%	0 6 min. (max.)
6-12A	150%	12 min. (max.)

Recommended signal block for

1/2" x 2" indicating fuses

- Page 45



KAZ

Specifications

Description: Non-Fuse actuator.

Dimensions: 1/2" x 2"
(10.3 x 50.8mm).

Ratings:

Volts — 600Vac
Amps — N/A
IR — 200kA

Agency Information: CE, UL Listed, Guide JDVS, File E58836.

Features and Benefits

- Bussmann signal blocks 2778, 2837 or 2838 with KAZ actuators mounted in parallel with fuses having a rating of 50A or larger to provide blown fuse dropout of shunt-trip fused switches.
- Type KAZ can be used in circuits rated 600V or less.
- Type KAZ has an interrupting rating of 200kA.

Typical Applications

- Large, Shunt-Trip Fused Switches
- Fuse Protected Circuits Rated 50A or Larger With Shunt-Trip Devices.

Catalog Number: KAZ

Recommended signal block for

1/2" x 2" indicating fuses

- Page 45

Data Sheet: 2021



4164 & 4164-FR Limiter Blocks

Specifications

Description: Limiter fuse blocks for ANL & ANN.

- 4164 furnished with nylon inserted locknuts
- 4164-FR furnished with standard hex nuts

Dimensions: Length: 3.38"
Width: 0.95"
Height: 1.62"

Studs center to center: 2.43"



Ratings:

Volts — 125Vac
— 80Vdc

Amps — 10-800A

Poles: 1 - stud terminal

In-line Size Rejecting Fuses and Fuse Holders

GLQ

Specifications

Class: Supplemental

Description: Fast-acting, size-rejecting in-line fuse.

Construction: Glass tube.

Ratings:

Volts — 300Vac (or less)

Amps — 1-10A

IR — 10kA

Agency Information: CE, Std. 248-14, UL Listed (Guide JDYX, File E19180), CSA Certified, (Class 1422-01, File 53787).

Features and Benefits

- In-Line, fast-acting circuit protection.
- Rejection feature prevents overfusing.

Typical Applications

- In-line Lighting Ballast Protection

Catalog Numbers (Amps) and Rejection Holders

Fuse	Holder ^{1, 2}	Fuse	Holder ^{1, 2}
GLQ-1	HLO-1- $\frac{1}{10}$	GLQ-3	HLO-3- $\frac{2}{10}$
GLQ-1- $\frac{1}{2}$	HLO-1- $\frac{1}{10}$	GLQ-4	HLO-5
GLQ-1- $\frac{9}{10}$	HLO-1- $\frac{1}{10}$	GLQ-5	HLO-5
GLQ-2	HLO-3- $\frac{2}{10}$	GLQ-9	HLO-10
GLQ-2- $\frac{1}{2}$	HLO-3- $\frac{2}{10}$	GLQ-10	HLO-10

- Carrier is UL Recognized, Guide IZLT2, File E14853 and CSA Certified, Class 6225-01, File 47235 10A, 300Vac.
- Units can be panel-mounted either in a knockout hole with a separate steel clip (BK/A-104) or in a keyhole punch using separate mounting clip #6374 for panels of thickness 0.043" to 0.062" or #4909 for thickness 0.030" to 0.042".
 - Do not put tension on line (rear) terminal of fuse holder.

Data Sheet: 2033



GMO

Specifications

Class: Supplemental

Description: Time-delay, size-rejecting in-line fuse.

Construction: Ceramic tube.

Ratings:

Volts — 300Vac (or less)

Amps — $\frac{1}{2}$ -6 $\frac{1}{4}$ A

IR — 10kA

Agency Information: CE, Std. 248-14, UL Listed (Guide JDYX, File E19180), CSA Certified, (Class 1422-01, File 53787)

Features and Benefits

- In-line, fast-acting circuit protection.
- Rejection feature prevents overfusing.

Typical Applications

- In-Line Lighting Ballast Protection

Catalog Numbers (Amps) and Rejection Holders

Fuse	Holders ^{3, 4}	Fuse	Holders ^{3, 4}
GMO- $\frac{1}{2}$	HLO- $\frac{1}{2}$	GMO-2- $\frac{1}{2}$	HLO-3- $\frac{2}{10}$
GMO- $\frac{9}{10}$	HLO-1- $\frac{1}{10}$	GMO-3	HLO-3- $\frac{2}{10}$
GMO- $\frac{9}{10}$	HLO-1- $\frac{1}{10}$	GMO-3- $\frac{2}{10}$	HLO-3- $\frac{2}{10}$
GMO-1	HLO-1- $\frac{1}{10}$	GMO-4	HLO-5
GMO-1- $\frac{1}{4}$	HLO-1- $\frac{1}{10}$	GMO-6	HLO-8
GMO-1- $\frac{9}{10}$	HLO-1- $\frac{1}{10}$	GMO-6- $\frac{1}{4}$	
GMO-2	HLO-3- $\frac{2}{10}$		

- Carrier is UL Recognized, Guide IZLT2, File E14853 and CSA Certified, Class 6225-01, File 47235 10A, 300Vac.
- Units can be panel-mounted either in a knockout hole with a separate steel clip (BK/A-104) or in a keyhole punch using separate mounting clip #6374 for panels of thickness 0.043" to 0.062" or #4909 for thickness 0.030" to 0.042".
 - Do not put tension on line (rear) terminal of fuse holder.

Data Sheet: 2030



Low Voltage Supplementary Fuses



HLQ³ Fuse Holders
for both GLQ & GMO fuses.

In-line Non-rejecting Fuses and Fuse Holders

GLR

Specifications

Class: Supplemental

Description: Fast-acting, non-rejection, in-line fuse.

Construction: Glass tube.

Ratings:

Volts — 300Vac (or less)

Amps — $\frac{3}{16}$ -15A

IR — 10kA

Agency Information: CE, Std. 248-14, UL Listed, 0-15A/300Vac (Guide JDYX, File E19180), CSA Certified, 0-10A/300V (Class 1422-01, File 53787).

Features and Benefits

- In-line, fast-acting circuit protection.

Typical Applications

- In-Line Lighting Ballast Protection

Catalog Numbers (Amps) and Non-Rejection Holders

Fuse	Holder ^{1, 2*}	Fuse	Holder ^{1, 2*}
GLR- $\frac{3}{16}$	HLR	GLR-5	HLR
GLR- $\frac{1}{2}$	HLR	GLR-6	HLR
GLR-1	HLR	GLR-7	HLR
GLR-1- $\frac{1}{2}$	HLR	GLR-8	HLR
GLR-1- $\frac{3}{4}$	HLR	GLR-9	HLR
GLR-2	HLR	GLR-10	HLR
GLR-3	HLR	GLR-12	HLR
GLR-4	HLR	GLR-15	HLR-2A

1) Carrier is UL Recognized, Guide IZLT2, File E14853 and CSA Certified, Class 6225-01, File 47235 12A, 300Vac.

2) Units can be panel-mounted either in a knockout hole with a separate steel clip (BK/A-104) or in a keyhole punch using separate mounting clip #6374 for panels of thickness 0.043" to 0.062" or #4909 for thickness 0.030" to 0.042".

*** For two leads (one each for line and loadside) order HLR-2A, 15A, 300V**

- An alternative to the HLR fuse holder is the A fuse holder. The A fuse holder comes *WITHOUT* leads. The customer inserts #18 insulated solid copper wire into the line side receptacle as well as into the load side receptacle. It has the same body dimensions, utilizes the same mounting hole, and takes the same mounting clips as the HLR. The A fuse holder is UL Recognized, 10A, 300Vac, Guide IZLT2, File E14853 and CSA Certified, 10A, 300Vac, Class 6225-01, File 47235.
- Do not put tension on line (rear) terminal of fuse holder.

Data Sheet: 2032



HLR-2A Fuse Holder

GMF

GRF

Specifications

Class: Supplemental

Description: Time-delay, non-rejection, in-line fuse.

Construction: Glass tube.

Ratings:

Volts — 300Vac (or less)

Amps — $\frac{3}{10}$ -10A

IR — 10kA

Agency Information: CE, Std. 248-14 0-10A, UL Listed (Guide JDYX, File E19180), CSA Certified, (Class 1422-01, File 53787).

Features and Benefits

- In-line, time-delay circuits protection.

Typical Applications

- In-Line Lighting Ballast Protection

Catalog Numbers (-Amps) and Non-Rejection Holders

Fuse	Holder ^{3, 4*}	Fuse	Holder ^{3, 4*}
GMF- $\frac{3}{10}$	HLR	GMF-3	HLR
GMF- $\frac{1}{2}$	HLR	GMF-3- $\frac{3}{10}$	HLR
GMF- $\frac{3}{4}$	HLR	GMF-4	HLR
GMF- $\frac{9}{10}$	HLR	GMF-5	HLR
GMF-1	HLR	GMF-6- $\frac{1}{4}$	HLR
GMF-1- $\frac{1}{4}$	HLR	GMF-10	HLR
GMF-1- $\frac{3}{10}$	HLR	GRF-7	HLR
GMF-2	HLR	GRF-8	HLR
GMF-2- $\frac{1}{2}$	HLR	GRF-10	HLR
GMF-2- $\frac{3}{10}$	HLR		

3) Carrier is UL Recognized, Guide IZLT2, File E14853 and CSA Certified, Class 6225-01, File 47235 12A, 300Vac.

4) Units can be panel-mounted either in a knockout hole with a separate steel clip (BK/A-104) or in a keyhole punch using separate mounting clip #6374 for panels of thickness 0.043" to 0.062" or #4909 for thickness 0.030" to 0.042".

***For two leads order HLR-2A, 15A, 300V**

- An alternative to the HLR fuse holder is the A fuse holder. The A fuse holder comes *WITHOUT* leads. The customer inserts #18 insulated solid copper wire into the line side receptacle as well as into the load side receptacle. It has the same body dimensions, utilizes the same mounting hole, and takes the same mounting clips as the HLR. The A fuse holder is UL Recognized, 10A, 300Vac, Guide IZLT2, File E14853 and CSA Certified, 10A, 300Vac, Class 6225-01, File 47235.
- Do not put tension on line (rear) terminal of fuse holder.

Data Sheet: 2031



HLR Fuse Holder

Automotive Blade-type Fuses

ATC® fuse



(Actual Size)

*Available
With
Indication*

Specifications

Description: Fast-acting blade fuse.

Construction: Colored plastic housing with zinc fuse element.

Ratings:

Volts — 32Vdc
Amps — 1-40A
IR — 1000A

Agency Information: UL Recognized, (3-40A) (Guide JFHR2, File E56412), SAE Standard J1284.

Features and Benefits

- Color coded plastic housing for easy identification of fuse ratings

Typical Applications

- Automotive

Catalog Numbers (Amps)

Catalog No. Non-Indicating	Indicating	Color
ATC-1		Black
ATC-2		Gray
ATC-3	ATC-3ID	Violet
ATC-4		Pink
ATC-5	ATC-5ID	Tan
ATC-7-1/2	ATC-7-1/2ID	Brown
ATC-10	ATC-10ID	Red
ATC-15	ATC-15ID	Blue
ATC-20	ATC-20ID	Yellow
ATC-25	ATC-25ID	Clear
ATC-30	ATC-30ID	Green
ATC-35	ATC-35ID	Blue-Green
ATC-40	ATC-40ID	Orange

Recommended in-line fuse holder for blade type fuses

- Page 56

Data Sheet: 2009

ATM Fuse



(Actual Size)

*Available
With
Indication*

Specifications

Description: Fast-acting blade fuse.

Construction: Colored plastic housing with zinc fuse element.

Ratings:

Volts — 32Vdc
Amps — 2-30A
IR — 1000A

Features and Benefits

- Color coded plastic housing for easy identification of fuse ratings

Typical Applications

- Automotive

Catalog Numbers (Amps)

Part No. Non-Indicating	Indicating	Low-Profile	Color
ATM-2			Gray
ATM-3	ATM-3ID		Violet
ATM-4			Pink
ATM-5	ATM-5ID	ATM-5LP	Tan
ATM-7-1/2	ATM-7-1/2ID	ATM-7-1/2LP	Brown
ATM-10	ATM-10ID	ATM-10LP	Red
ATM-15	ATM-15ID	ATM-15LP	Blue
ATM-20	ATM-20ID	ATM-20LP	Yellow
ATM-25	ATM-25ID	ATM-25LP	Clear
ATM-30	ATM-30ID	ATM-30LP	Green

Recommended in-line fuse holder for blade type fuses

- Page 56

Data Sheet: 2048

MAX Maxi-Fuse®

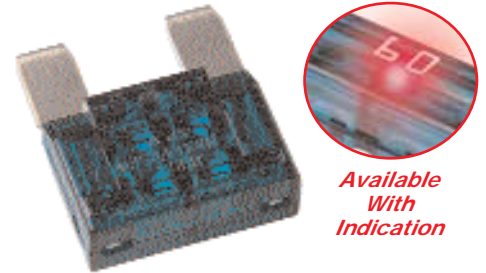

(Actual Size)

*Available
With
Indication*

Specifications

Description: Fast-acting blade fuse.

Construction: Colored plastic housing with zinc fuse element.

Ratings:

Volts — 32Vdc
Amps — 20-80A
IR — 1000A

Features and Benefits

- Color coded plastic housing for easy identification of fuse ratings

Typical Applications

- Automotive

Catalog Numbers (Amps)

Catalog No. Non-Indicating	Indicating	Color
MAX-20	MAX-20ID	Yellow
MAX-25		Gray
MAX-30	MAX-30ID	Green
MAX-35		Brown
MAX-40	MAX-40ID	Orange
MAX-50	MAX-50ID	Red
MAX-60	MAX-60ID	Blue
MAX-70	MAX-70ID	Tan
MAX-80	MAX-80ID	Clear
	MAX-100ID	Purple

Recommended in-line fuse holder for blade type fuses

- Page 56

Data Sheet: 2049

Low Voltage
Supplementary
Fuses

Automotive Blade-type Fuse Holders

HHC, HHD, HHF, HHG & ATC-FHID

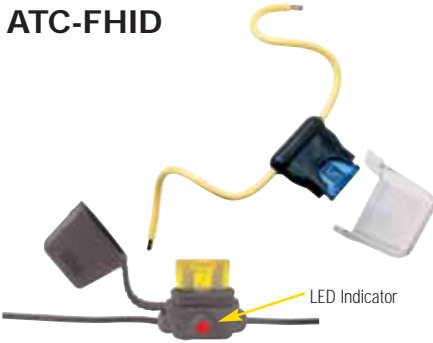

easyID™ LED Indicating Holder

Specifications

Description: In-line fuse holders for ATC® Blade-Type fuses.

Dimensions: See Dimensions illustration.

Ratings:

Volts: — 32Vdc

Amps: — 80% continuous of fuse rating. See Catalog Numbers table for individual fuses sizes.

Catalog Numbers

Catalog Numbers	Fuse Holder Description	Fuse Amps	Electrical Connection
HHC	Yellow	1-20	#16 black leadwire
HHD	Black	1-30	#12 yellow leadwire
HHD-C	HHD Cover only	—	Clear polycarbonate
HHF	Black w/ cover	1-20	#16 yellow leadwire
HHG	Black w/ cover	1-30	#12 yellow leadwire
ATC-FHID	Indicating Holder Black w/ cover	1-20	#16 black leadwire

Bulk Products (Quantity - 1000 Pieces)

Catalog Numbers	Fuse Holder Description	Fuse Amps	Electrical Connection
BK/HHC-R	Yellow	1-20	#16 red leadwire
BK/HHF-B	Black w/ cover	1-20	#16 black leadwire

A fuse must be properly and fully inserted into the holder to provide a solid connection. Poor or improper insertion of the fuse can result in failure of the fuse and holder, thus not protecting the device for which it was intended.

HHC & HHD Dimensions - in

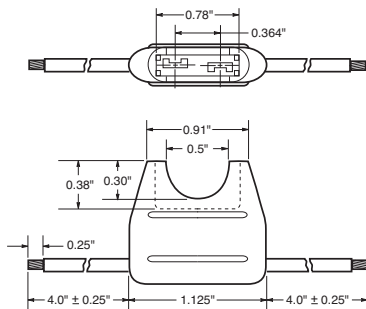

Data Sheet: 2107

HHL, HHM & ATM-FHID



easyID™ LED Indicating Holder

Specifications

Description: In-line fuse holders for ATM Fuses.

Ratings:

Volts: — 32Vdc

Amps: — 80% continuous of fuse rating. See Catalog Numbers table for individual fuses sizes.

Catalog Numbers

Catalog Numbers	Fuse Holder Description	Fuse Amps	Electrical Connection
HHL	Black w/ cover	2-20	#16 black leadwire, 4" length stripped to 1/4"
HHL-B	Black - body only	2-20	#16 black leadwire, 4" length stripped to 1/4"
HHM	Black w/ cover	2-30	#12 red leadwire, 4" length stripped to 1/4"
HHM-B	Black - body only	2-30	#12 red leadwire, 4" length stripped to 1/4"
HHM-C	Black - cover only	—	—
ATM-FHID	Indicating Holder Black w/ cover	1-20	#16 black leadwire

Bulk Products (Quantity - 1000 Pieces)

Catalog Numbers	Fuse Holder Description	Fuse Amps	Electrical Connection
BK/HHL-R	Black - w/cover	2-20	#16 red leadwire, 4" length stripped to 1/4"
BK/HHL-B	Black - body only	2-20	#16 black leadwire, 4" length stripped to 1/4"

A fuse must be properly and fully inserted into the holder to provide a solid connection. Poor or improper insertion of the fuse can result in failure of the fuse and holder, thus not protecting the device for which it was intended.

HHL & HHM Dimensions - in

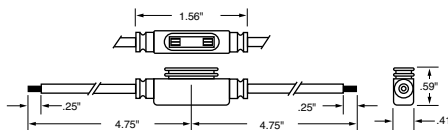

Data Sheet: 2128

HHX



Specifications

Description: In-line fuse holders for MAXI® Fuses.

Ratings:

Volts: — 32Vdc

Amps: — 80% continuous of fuse rating. See Catalog Numbers table for individual fuses sizes.

Catalog Numbers

Catalog Numbers	Fuse Holder Description	Fuse Amps	Electrical Connection
HHX	Black w/ cover	20-60	#6 red leadwire, 5" with blunt ends
HHX-B	Black - body only	20-60	#6 red leadwire, 5" with blunt ends
HHX-C	Black cover only	—	—

A fuse must be properly and fully inserted into the holder to provide a solid connection. Poor or improper insertion of the fuse can result in failure of the fuse and holder, thus not protecting the device for which it was intended.

Dimensions - in

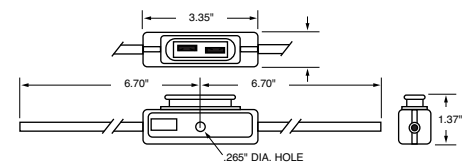

Data Sheet: 2129